

N4.38

Specifications

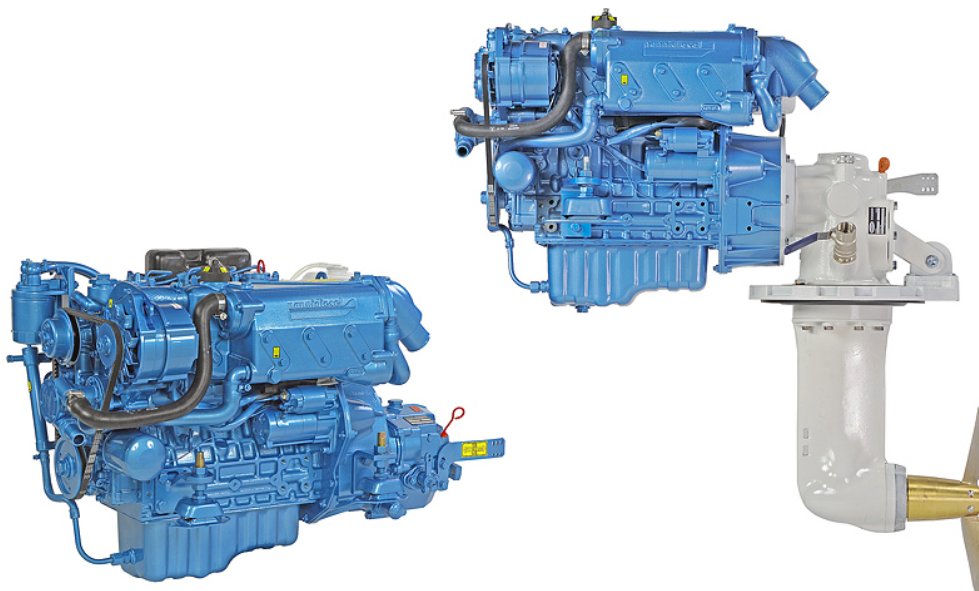

Power at crankshaft	27.6 kW [37.5 hp]
Displacement	1.498 l [91 in ³]
Configuration	4 cylinders in line
Operation type	4 stroke Diesel
Bore & Stroke	78 x 78.4 mm [3.07 x 3.09 in]
Compression ratio	23:1
Rated speed	3000 rpm
Idle speed	850 rpm
Peak torque	96 Nm
Peak torque speed	2200 rpm
Dry weight	
with Sail Drive SP60	184 kg [405 lb]
with TTMC35A	152 kg [335 lb]

Engine base	Kubota
Fuel system	Mechanical indirect injection
Air intake	Natural
Cooling	Closed cooling with heat exchanger
Mounting angle	15° Front up 15° Front down
Alternator	12 Volt 100 Amp
Rating	M4
Emission compliance	EPA marine Tier 3 RCD 94/25/EC BSO 2

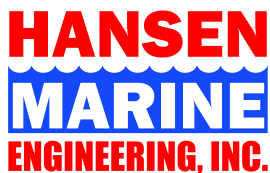

Hansen Marine
Engineering, Inc.
32 Tioga Way
Marblehead, MA 01945
800-343-0480
hansenmarine.com



N4.38

27.6 kW [37.5 hp] @ 3000 rpm

TECHNICAL DESCRIPTION

Engine block

- 4 cylinders in line
- Gear-driven valve train
- Watercooled exhaust manifold

Fuel system

- Mechanical governor
- Cam driven in-line injection pump
- Fuel feed pump with hand primer
- Fuel filter

Lubrication system

- Replaceable full-flow oil filter
- Oil dipstick
- Oil drain pump

Cooling system

- Closed cooling with heat exchanger
- Gear driven self-priming raw water pump
- Coolant circulating pump
- Water cooled exhaust elbow

Electrical system & Instrumentation

- 12V Electrical system
- 12V 100A alternator
- Electric starter motor
- Electric stop function
- Instrumentation panel, including Start/Stop, tachometer & alarms
- Extension cable harness with plug-in connection

Air intake

- Mounted air cleaner

Other features

- Flexible engine mounting
- Bracket for control cables

Optional equipment & accessories

- Keel cooling adaptation
- Complete marine propulsion systems
- Throttle and shift controls
- Additional instrumentation, Flying bridge extension harness
- Polyester frame (for Sail Drive version)
- Engine mounting adaptation
- Two pole electrical system
- Water boiler systems
- Stuffing box connections
- Complete fuel systems
- Complete exhaust systems
- SOLAS approved version
- 24V Electrical system

RATING

- Up to 3000 annual operating hours
- Load factor up to 40%
- Full power for no more than 1 hour out of each 12 hours of operation. The remaining operation time must be at or below cruising speed

TRANSMISSIONS

Shaft line

- TMC60
- TTMC35A
- TTMC35P
- ZF12
- ZF12M
- ZF25A

Sail Drive

- SP60

Contact your local dealer for more details and availability for transmission model and type.

PERFORMANCE CURVES

Power at crankshaft

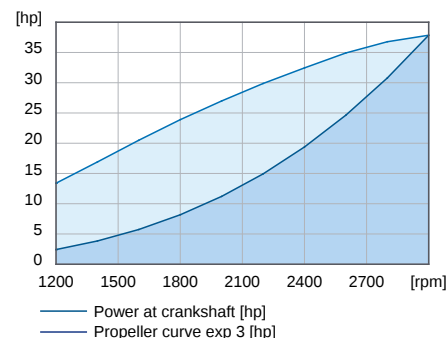

Torque at crankshaft

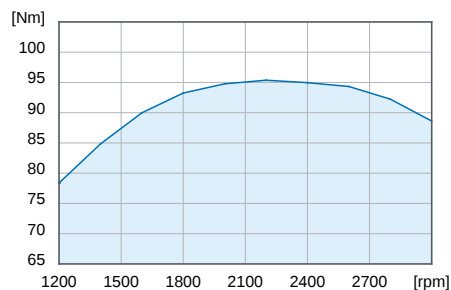

Fuel consumption

At calculated propeller load exp 3

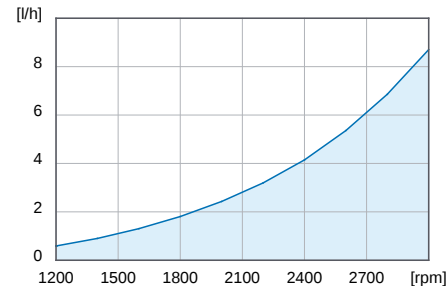

DIMENSIONS WITH SP60 / TMC60

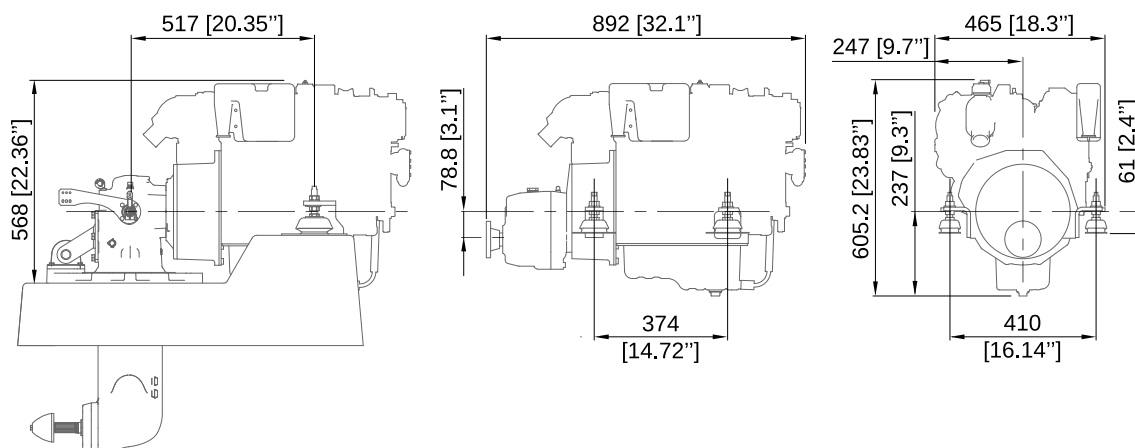

Nanni Industries S.A.S. France

11, Avenue Mariotte - Zone Industrielle
33260 La Teste - France
Tel: +33 (0)5 56 22 30 60
Fax: +33 (0)5 56 22 30 79

Nanni Trading S.R.L.

Via Degli Olmetti, 5/B
00060 Formello (RM) - Italia
Tel: +39 (0)6 30 88 42 51/52/53
Fax: +39 (0)6 30 88 42 54

Technical data according to ISO 8665. Specifications are subject to change without notice. Images and illustrations may show non standard equipments. All combination of equipment & accessory are not available.

150715-ENG